

WOODWARM STOVES

Installation and Operating Instructions for The Fox Fire Free Standing Multi Fuel Stove.

*Please read this booklet thoroughly before attempting to install or use
this appliance.*

Includes Registration and Guarantee Document.



Serial Number

*Also detailed on data plate located on the back of the stove.
Please quote when making an enquiry.*

M 100 : _____

A new era in clean, effective multi-fuel stoves.

WOODWARM STOVES

Woodwarm Stoves (Est. 1974)

By

Metal Developments Ltd

The Workshop, Wheatcroft Farm, Cullompton, Devon EX15 1RA

Tel : 01884 35806 Fax : 01884 35505

www.woodwarmstoves.co.uk



List of Contents

General Specifications	Page 3
Cautionary Notes on Use	Page 4
Regulations and Installation Instructions	Page 4
Hearth	Page 4
Stove Site and Minimum Clearances	Page 5
Chimney and Flue	Page 5
Air Ventilation and Free Air	Page 5
Flue Appliance Outlet Positions	Page 6
Flue Outlet Configuration	Page 7
Installing the Stove	Page 8
Baffle	Page 8
Internal Fireboards	Page 8
Fire Doors	Page 9
Glass Panels—Cleaning and replacement	Page 10
Operation of the Grate	Page 11
Commissioning	Page 11
Fuels for Burning on Fireview Stoves	Page 12
Daily Routine, Maintenance and Servicing	Page 12
Operating Instructions for the Woodwarm Fireview Stoves	
How Clean Burn Works	Page 14
Initial Lighting	Page 14
Lighting	Page 14
To Achieve Cleanburn	Page 14
Overnight Burning	Page 15
Fault Finding	Page 16
Fume Emission	Page 17
The Woodwarm Guarantee	Page 17
Details of Product Registration	Page 18
Spare Parts	Page 18
Useful Contacts	Page 19

General Specifications - Fox Fire Freestanding Stove



Class 1: BS EN 13240:2001 + Amd 2:2004.

For Intermittent use only.

Unsuitable for use in a shared flue system.

Use only recommended fuels.

Table 1

Air Inlet grills must be so positioned that they are not liable to blockage.

Nominal Heat Output Kw	4.2-4.3
Space Heating Kw	4.2-4.3
Efficiency %(wood)	82
Flue Gas mass flow g/s (wood)	3.3
Mean Flue gas Temp °C (wood)	203
Efficiency %(ancit)	82.1
Flue Gas mass flow g/s (ancit)	2.2
Mean Flue gas Temp °C (ancit)	173
Weight	
Minimum Clearance From Inflammables (without Woodwarm heat deflector)	
Rear	400mm
Side	400mm
Minimum Clearance From Inflammables (with Woodwarm heat deflector)	
Rear	220mm
Side	110mm
Recommended Refuelling Intervals	
Solid Fuel (hours)	1.5
Wood (hours)	1.5
Maximum Log Length	300mm
Overall Height	530mm
Overall Width	435mm
Overall Depth	370mm
Flue Outlet Size	125mm
Height to Centre of The Rear Flue	425mm
Top Flue - Centre Line To Rear	135mm
Stove Fire Boards	
Side Board(mm) (2 Required)	240x230mm
Rear Board (mm)	320x195mm

Cautionary Notes on Use

De-Ashing

To ensure that the stove will not overfire whilst the door is open, we would strongly recommend that de-ashing is only undertaken when the fuel load is almost exhausted, the stove is out or in a very low state.

Maximum Temperature - Over-firing the Stove - Use Beyond the Rated Output

The stove body is designed to run up to a maximum temperature **not exceeding 700F or 400C (the stove firedoor must be kept shut at all times except when re-fuelling or de-ashing the stove)**. We recommend the use of a stove thermometer available from your dealer or us.

There are 3 possible causes for stoves over-heating :-

1. After de-ashing as above, primary air vents left open.
2. The fire door rope seal worn or damaged or missing. This should be replaced if necessary or can be pulled out, adjusted and easily re-placed in their channels. No fixative is needed.
3. Excessive chimney draw (the minimum flue draft for nominal heat output is:- not exceeding 0.15 mbar (0.06" water gauge)). If it is high use remedial action; either the fitting of a flue stabiliser to the flue as close to the appliance as is aesthetically possible, the fitting of a flue damper in the chimney, or a chimney cowl. (Ask your dealer or contact us for details).

Chipboard and other composite wood-type materials contain corrosive additives, as do sulphurous coal products especially when mixed with wet wood, these may etch and permanently damage the surface of the glass.

REGULATIONS AND INSTALLATION INSTRUCTIONS FOR THE WOODWARM FIREVIEW STOVES

All local regulations, including those referring to national and European Standards (BS 6461, Installation of chimneys and flues for domestic appliances burning solid fuel (including wood and peat) & BS 8303, Code of practice for installation of domestic heating and cooking appliances burning solid mineral fuel) need to be complied with when installing this appliance.

Health and Safety at Work

It is the responsibility of the installer to comply with current Health and Safety Regulations, and particular attention should be given to the following:-

Asbestos

This stove contains no asbestos. If there is a possibility of disturbing any asbestos in the course of installation then please seek specialist guidance and use appropriate protective equipment.

Handling

This stove is heavy and adequate facilities must be available for all handling operations and its final manoeuvre into position. In order to lighten the stove, the main door may be removed. The baffle and grate bars can also be removed.

Glass

Care should be taken when handling the door that the glass is not knocked. The door is double glazed.

Fire Cement

Some types of Fire Cement are caustic and should not be allowed to come into contact with the skin. In cases of contact, wash off with plenty of water.

Electrical

If any electrical components are used in the installation they should be installed in accordance with the manufacturers installation instructions and all wiring must comply with the current I.E.E regulations and the by-laws of the local water authority.

Air Supply

Building Regulations dictate that an air vent of some type (usually an air brick) must be fitted into an exterior wall to allow sufficient flow of air into the fire. **Air Inlet grills must be so positioned that they are not liable to blockage.**

This stove should not be fitted in a room where an extractor fan is in use, as this could result in flue reversal and the emission of flue gases into the room.

HEARTH

The stove must stand on a fireproof hearth which must be at least **127mm thick and constructed of a non-combustible material**. The positioning of the stove and the size of the hearth is governed by Building Regulations for Class 1 Appliances. These regulations state that the hearth must extend at least **225mm** in front and **152mm** to the side of the stove. This can be covered with decorative tiles so long as these are also non-combustible.

SUPER IMPOSED HEARTH

In certain circumstances Building Regulations allow for a super imposed hearth. **This must be a minimum 12mm non-combustible material** e.g. slate, glass, steel. When the stove is raised **100mm** or more (with Woodwarm accessories e.g. legs, plinth, pedestal) the hearth temperature does not exceed **100°C**, which complies with Building Regulations.

STOVE SITE AND MINIMUM CLEARANCES

There must be **no combustible** material (i.e. plaster board, wooden wall panels, skirting boards, beams etc) **within a specified distance to the rear and sides of the stove, these can be found on table 1 page 3.**

The clearance between the stove and any non-combustible surface is recommended as **not less than 152mm.**

To reduce the above clearances further we recommend the use of the **Woodwarm Heat deflector**, these can be wall mounted to the rear or the sides of the stove.

CHIMNEY AND FLUE

The chimney should be thoroughly swept and examined for soundness. If the chimney is not lined, then we recommend strongly that before use it is fully lined with a **Class 1 Liner and insulated (we recommend no more than 600mm single skin flue from the appliance).** **It is not advisable to only partially line a chimney as this will only create further problems where the lining finishes.** If there are even the smallest air breaks in the mortar, the chimney is not suitable for a wood stove. When hot flue gases rise up the chimney, it will pull cold air through any small break. This cools the flue gases at that level causing wood tar to precipitate at that point on the chimney wall. Soon this will accumulate across the chimney and therefore constrict it and stop the fire burning properly. Eventually this will not only lead to a chimney fire, but will further rot the chimney structure. If the chimney is not lined and was previously used for an open fire then there is a possibility that the higher temperatures produced by this closed appliance will loosen deposits. It will be necessary to have the flue swept and inspected by a registered sweep one month after the initial installation.

In the absence of a chimney one of the following must be used either internally or externally:- a prefabricated block chimney, a conventionally constructed chimney with a Class 1 liner, or a twin walled insulated flue to BS 4543. **The internal diameter must not be less than that of your particular appliance.** Flues must be fitted in accordance with the manufacturers' instructions and according to local Building Regulations. If there is any doubt over the flue connection or the installation, consult your nearest professional installer, or the Building Inspector at your local council.

Whichever chimney option you choose to use **DO NOT FORGET TO POSITION A CLEANING ACCESS** (if applicable) in your flue and chimney that is easily accessible for sweeping. **Note:** Clay liners can create a cool upper internal temperature which can lead to condensation problems, especially if the liners are not back insulated. If a clay liner is already in place we recommend lining with class 1 liner.

For efficient stove working it is important to make sure that there is an adequate draw on the chimney. The chimney height should not be less than 4.5 metres measured vertically from the outlet of the stove to the top of the chimney. With a minimum flue draft reading of 0.05mbar (0.02"wg) when warm, increasing to 0.15mbar (0.06"wg) when hot. These readings should be taken using secondary air and all fire doors closed. The minimum flue size for these stoves varies according to the model, refer to the specification sheet (table 1 page 3) for the minimum flue diameter. If possible line the chimney with a flue liner that is at least 25mm (1") larger than that of your particular stove. At no point in the flue should it be below the minimum flue diameter.

When the stove is to be connected to an existing fireplace, this will need sealing to the flue by a register plate, which can be mounted horizontally or vertically.

This appliance is unsuitable for use in a shared flue system. If elsewhere in the house another fireplace feeds into the same chimney this **must** be sealed, otherwise flue gases or air may either be drawn into or escape from, the other chimney or fireplace. This would contravene Building Regulations as it is potentially **very dangerous.**

CHIMNEYS, FLUES, COMBUSTION, AIR SUPPLY AND POSITIONING OF THE STOVE

In addition to these installation instructions, Building Regulations and Local Authority By-Laws regarding flues and positioning of the appliance. (Building Regulations **Document J** must be observed).

AIR VENTILATION AND FREE AIR:

The stove requires 550 mm² of FREE AIR space per KW input in excess of 5kw. Therefore, a 9kw input appliance requires 2200mm² of free air.

$$9KW - 5KW = 4KW$$

$$4KW \times 550mm^2 = 2200mm^2$$

There must not be an extractor fan fitted in the same room as the stove as this can cause the stove to emit fumes into the room.

Flue Appliance Outlet Positions

Diagram 1

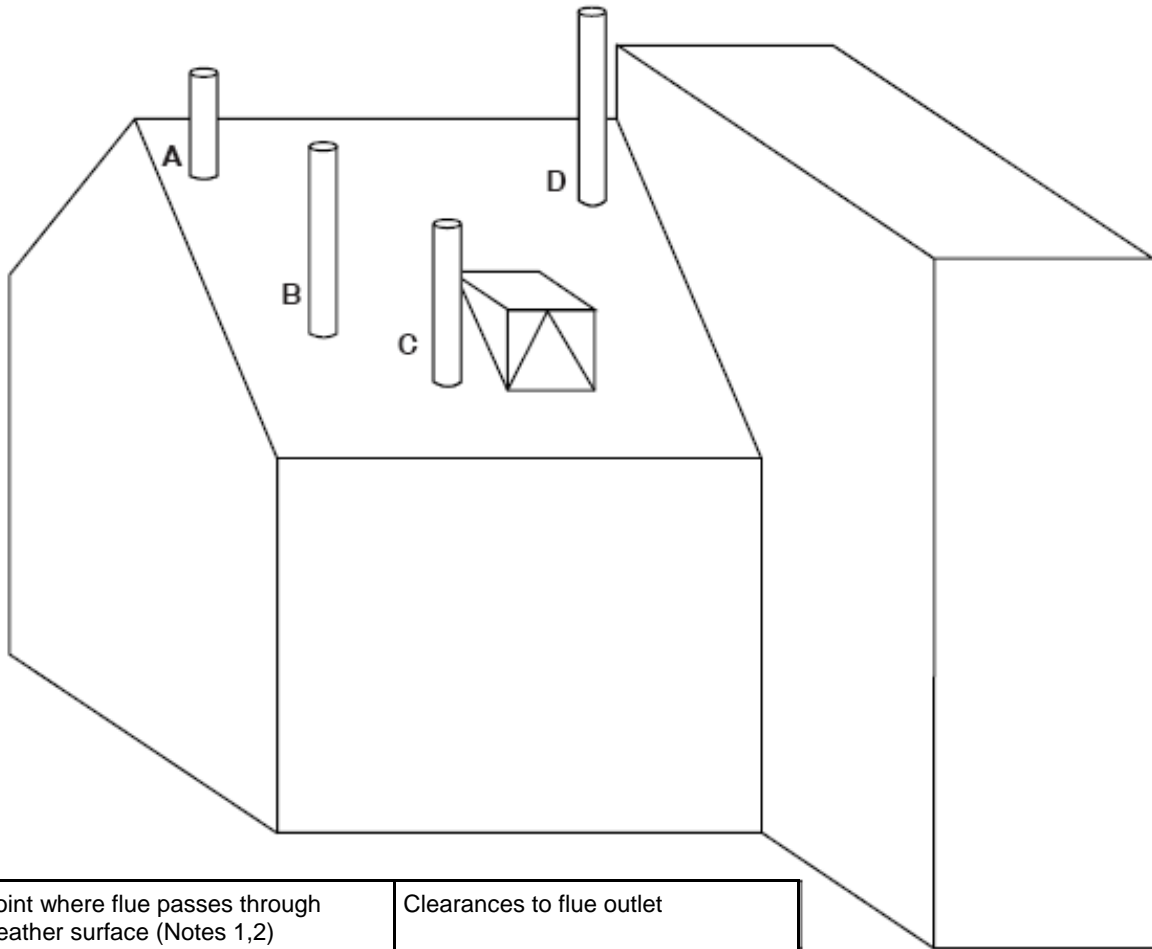

Point where flue passes through weather surface (Notes 1,2)		Clearances to flue outlet
A	at or within 600mm of the ridge.	at least 600mm above the ridge.
B	elsewhere on a roof (weather pitched or flat)	at least 2300mm horizontally from the nearest point on the weather surface and: a) at least 1000mm above the highest point of intersection of the chimney and the weather surface; or b) At least as high as the ridge.
C	below (on a pitched roof) or within 2300mm horizontally to an openable roof-light, dormer window or other opening. (Note 3)	At least 1000mm above the top of the opening.
D	within 2300mm of an adjoining or adjacent building, whether or not beyond the boundary. (Note 3)	at least 600mm above the adjacent building.
Notes 1) The weather surface is the building external surface, such as its roof, tiles or external walls. 2) A flat roof has a pitch less than 10°. 3) The clearances given for A and B, as appropriate, will also apply.		

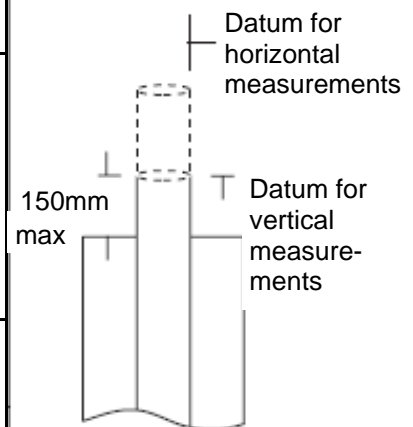

The datum for vertical measurements is the point of discharge of the flue, or 150mm above the insulation, whichever is the lower

Flue Outlet Configuration

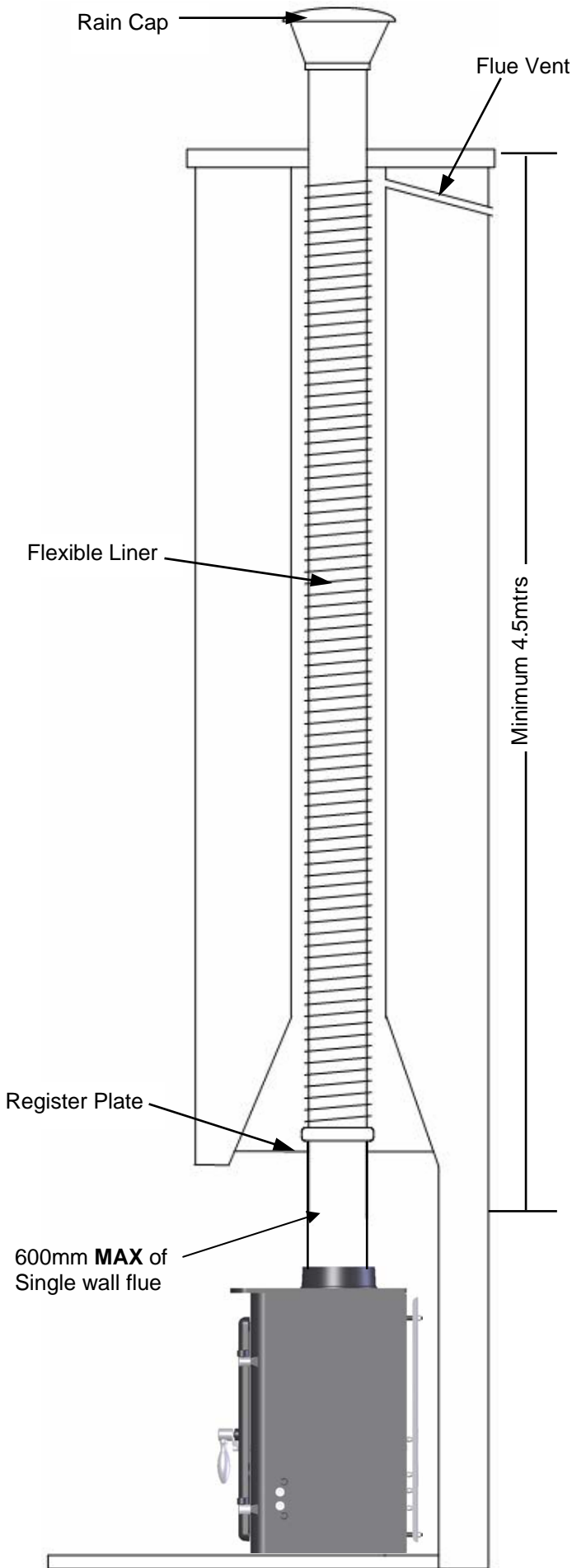
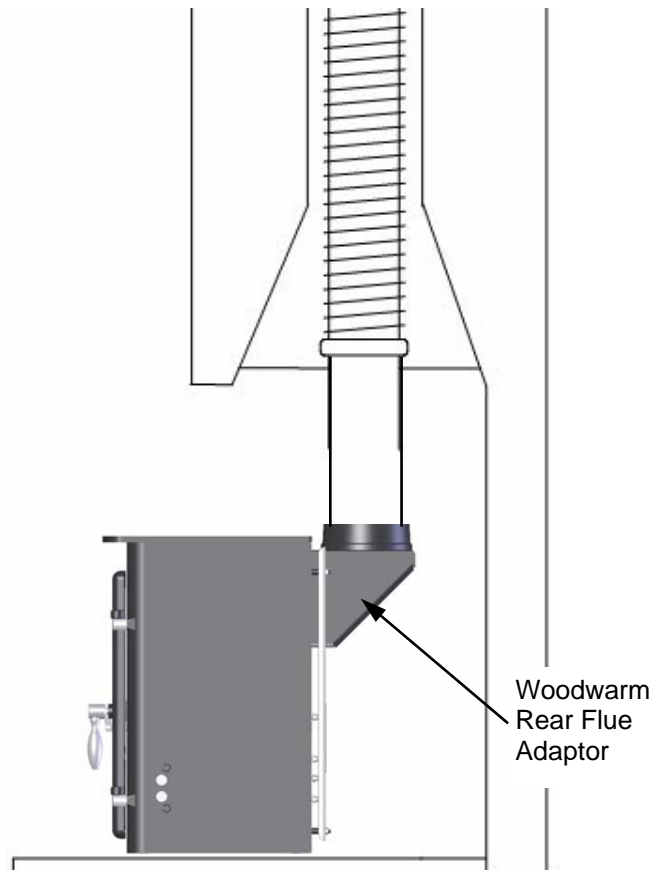
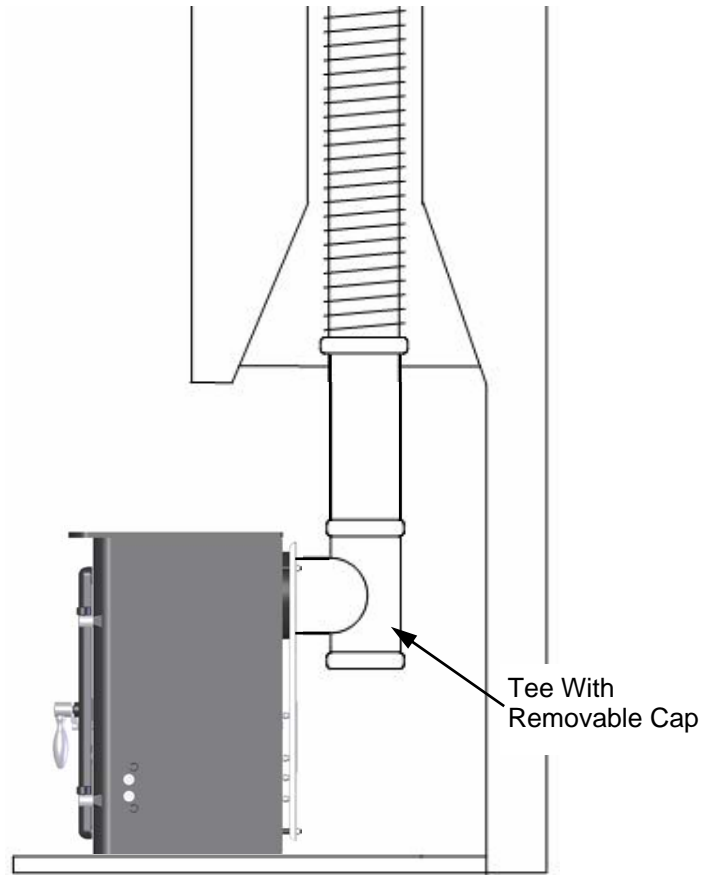

Diagram 2



INSTALLING THE STOVE

Remember to leave sufficient clearance in front of the stove for the fire door to open fully. Place stove on chosen level hearth and remove any packaging materials. The shrink polythene can be used as a cover for the stove whilst installation is in progress as fire cement will mark the stove paint surface if left.

There is normally a piece of **cardboard** , for protection, behind the door glass. All other pieces of board in the stove are the **fire boards**. Turn the handle and open the fire door then carefully remove it by lifting up and off its hinge pins (retaining these) and place it safely out of the way. From the front of the stove you can now remove **the operating tool, baffle, fire boards, the grate bars and ashpan** if necessary.

The **ashpan** can be used for holding the **grate bars** if you need to remove them, which can be done easily by rotating them fully open then lifting each one out of the **grate link bar**, outwards and upwards.

The flue spigot supplied with the Woodwarm is 127mm. It is designed to be used for top or rear mounting and is interchangeable with the blanking plate if a different flue position is required at a later date. There is a rope seal on both the blanking plate and the flue spigot to ensure an air tight seal. Locate the **blanking plate** and the **flue spigot** in their chosen apertures and then tighten the screws and nuts to secure them in place. **Ensure seal is secure and airtight.**

Fire cement and/or a length of fireproof rope should be used to seal the join of the **flue pipe** and the flue spigot, the joint between two **flue pipes** and where the flue pipe joins your chosen **register plate**. Stainless Steel self-tapping screws or nuts and set screws should be used to reinforce the above joints where applicable.

Carefully remove any excess fire cement immediately to ensure no marking of the stove finish.

Replace the baffle, grate bars and log guard followed by the ashpan and finally the fire door. (**For fitting of fire boards and baffle see diagram 3**).

BAFFLE

The smoke baffle sits on the rear fire board and locates on the baffle support pins in the top of the stove (front pins on two pin models) . Fit baffle as shown in Diagram 3. Ensure baffle seats squarely on rear board.

INTERNAL FIRE BOARDS

These stoves are for both wood and solid fuel and the interior of the fire chamber of all of them is lined with 30mm Mica based fire resistant board . There are three pieces, one at the rear under the baffle and flue outlet and one on either side of the stove. These fire boards are ready cut, to size and shape and may be packed loose to prevent damage. They are very fragile so **handle with care**, especially when loading with fuel. They have a relatively short life, especially when burning coal, so do inspect them regularly and replace if they begin to deteriorate by showing signs of breaking up or wearing thin. The fire board is important for efficient combustion and is not covered by any warranty as it is considered a consumable product.

The replacement sizes is provided under **Stove Fire boards** on **table 1 page 3**.

Fitting of Fire Board and Baffle

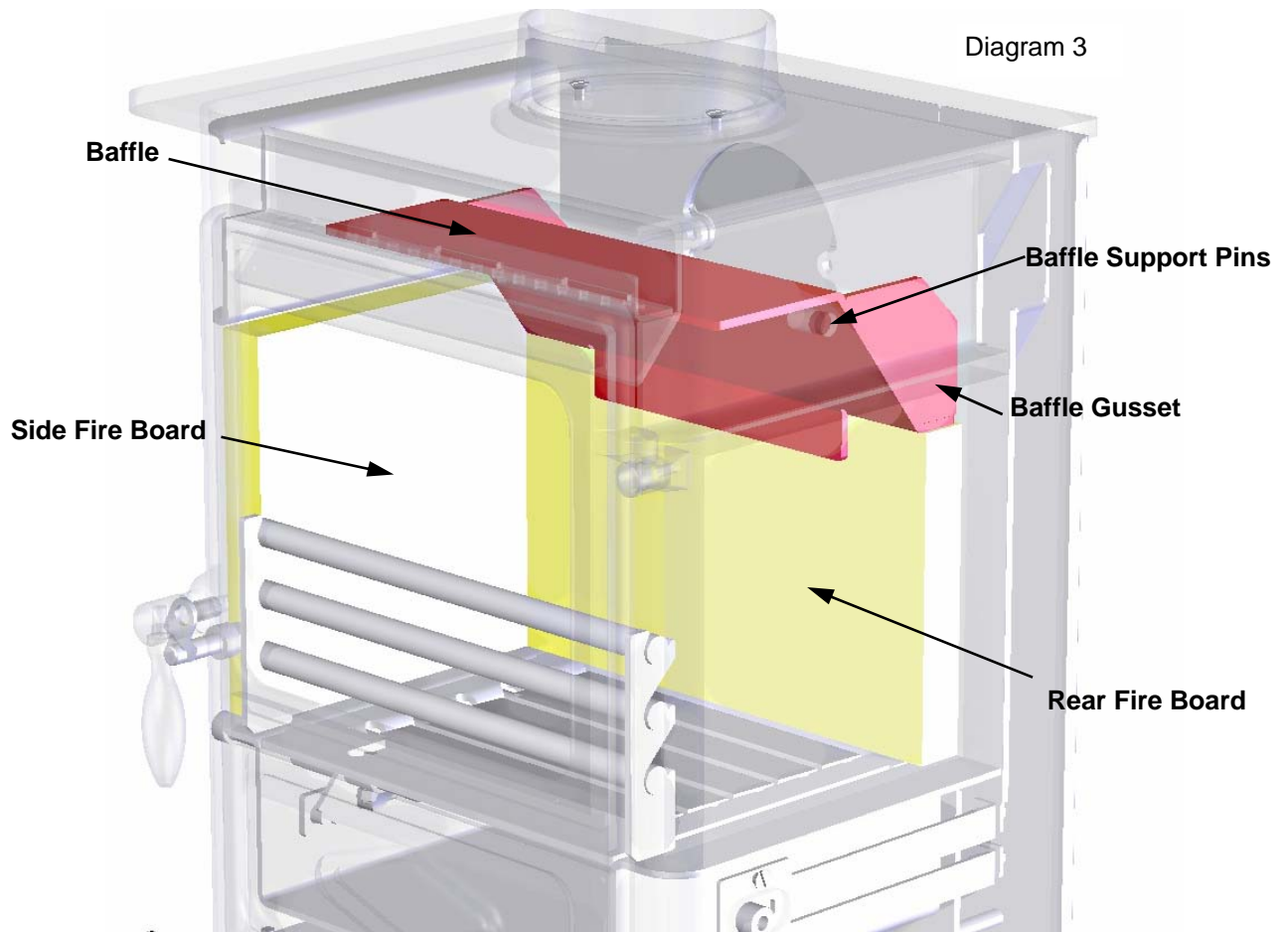

FIRE DOORS FOR ALL MODELS

Check when refitting the fire door that the rope seal on the inner face of the door is making an even contact with the stove body when the door is closed. Your Fire Fox Stove has a door handle (shown below in red) to make it easier and safer to use your stove. Use the heat resistant glove provided to operate the door handle, turn to clockwise to open and turn anti-clockwise to lock. If necessary this door catch can be adjusted, by rotating the door handle 360° anti-clockwise to tighten the door seal, and 360° clockwise to loosen seal.



GLASS PANELS AND CLEANING

There are two panels of glass in each door. They are made of a heat resistant ceramic product which will not break with the heat of the fire. However, it is important to maintain the movement of the glass within the door as, if the glass is restricted, it is likely to crack with the expansion or contraction of the cast door. To achieve this it has heat resistant fibre glass ladder rope around the edges and this should be replaced if it is showing signs of deterioration.

The glass can be cleaned when hot without damage to the panel although care must be taken not to burn your fingers etc., also care must be taken with aerosol cleaners and cleaning cloths. We recommend the proprietary stove glass cleaners. When solid fuel is being burnt any sooty deposits on the glass can be cleaned simply by wiping with a dry cloth.

If the stove glass becomes dirty this is either due to the closing of the airwash before the fuel is up to temperature and/or wood fuel is too wet. If a routine is established of hard burning on secondary air only for 20 minutes at each end of the day this will assist in keeping your glass clean.

REPLACEMENT OF GLASS PANELS

Carefully lift the fire door from its hinge pins and lay it down - preferably on a soft substance - being aware of the door fastening catch. The outer glass panel (furthest from the fire) is mounted on fibre glass ladder rope which should surround all the edges (diagram 5). Caution is required when replacing this glass panel as the ladder rope has a tendency to slip out of position as the glass is fitted. The second or inner panel then fits directly on top of the outer followed by the top and bottom steel glass retainer and the whole held together by the 4 x (M4 x 10mm) machine screws. It is recommended to apply some heat resistant copper grease or graphite grease to the screws and **DO NOT OVER TIGHTEN THEM** as the glass panels will crack.

The stove requires both of these glass panels in place to achieve a clean burn state as they act in a similar way to double glazing in a domestic window.

Diagram 5

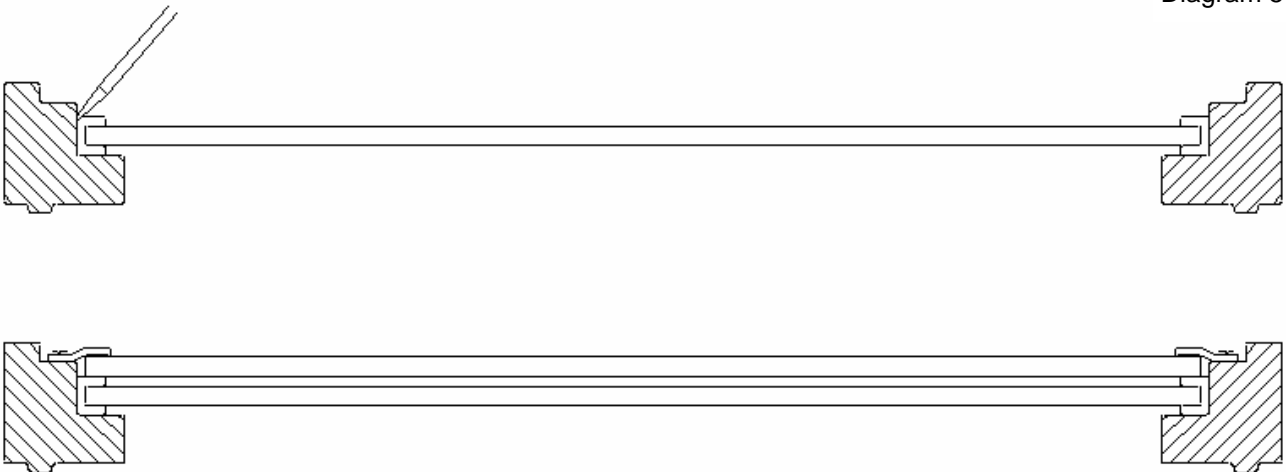

OPERATION OF GRATE

Your stove is fitted with a **multi-fuel grate** (diagram 6 & 6A) which will enable you to burn wood or solid fuel equally effectively. It consists of a grate lever operating handle (shown in yellow), grate bars (shown in blue) and the grate link bar (shown in pink). Once fuel is loaded on the grate the grate will remain where it has been positioned). The grate is left with the bars closed for wood and slightly open for solid fuel, to de-ash **gently** and **NOT FORCEFULLY** rotate the bars fully. Never allow ashes to accumulate underneath the grate to the point where they come in contact with the grate bars, they will overheat and distort, nor to the point where the ash will obstruct the grate link bar thus the grate bars will not be able to be rotated.

DE-ASHING

Using the tool provided (shown in yellow) the grate is **gently** and **NOT FORCEFULLY** rotated clockwise to open and to de-ash and anti-clockwise to close and for the wood burning mode. A **GENTLE ROCKING** movement will dislodge all but the largest clinkers through to the ashpan. Too much riddling/poking can result in unburnt fuel being emptied into the ash pan and should be avoided. Any clinkers should be regularly removed from the fire bed. In the larger models there are two ashpans for ease of use. The ashpan should be emptied regularly before it becomes too full. Use the operating tool to handle the ashpan, taking care not to spill the ashes as there may well be hot embers still glowing in the pan. **Never allow ash to accumulate in the ashpan** so that it comes into contact with the underside of the grate as this could impede the movement of the grate link bar and therefore the movement of the grate bars and **will cause serious damage to the grate bars**. Care should be taken that ash is cool before emptying into plastic bin liners. If the grate bars will not rotate easily **DO NOT FORCE** them but investigate the possible cause, i.e. clinker or nails blocking movement or too much ash in ashpan and in the bottom of stove, and remedy as soon as possible.

“Tippy” ash caddies are available from your local stockist to assist in the removal of ashes from the house.

Diagram 6

Diagram 6A

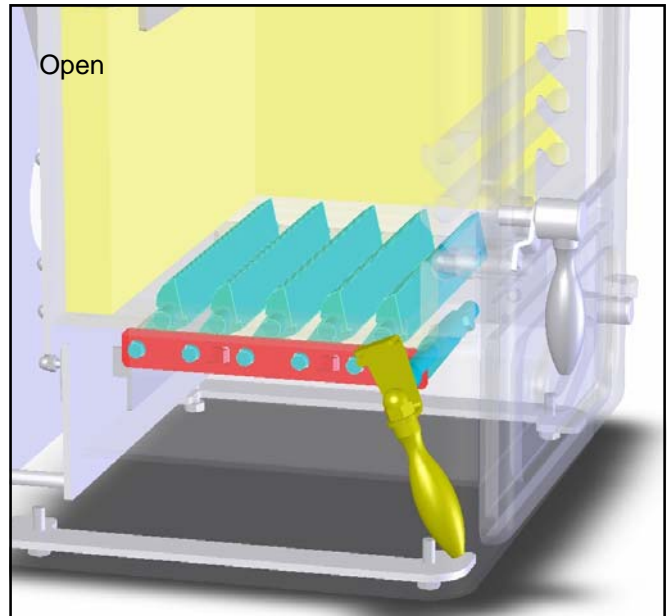
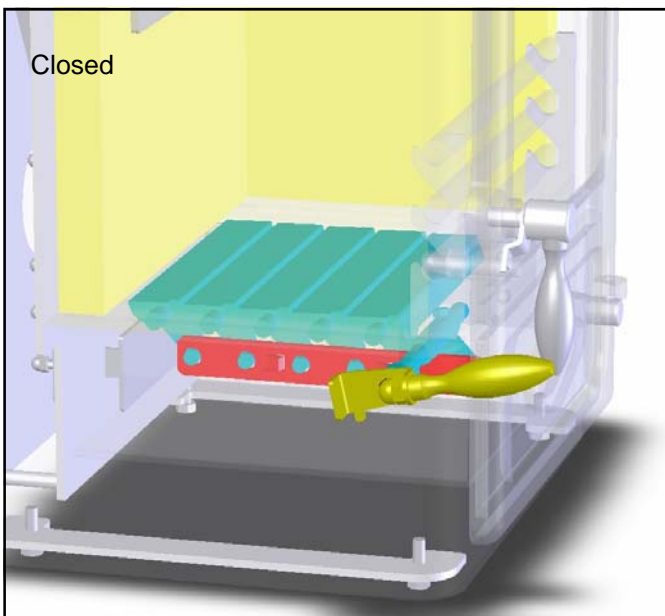

COMMISSIONING

On completion of the installation and after allowing a suitable period of time for any fire cement or mortar joints to dry out, the stove should be cleaned using a soft dry cloth. Check joints and seals. The stove can then be lit and checked to ensure that smoke is taken from the appliance up the chimney and emitted safely.

The customer should be advised on the use of the appliance.

On completion of the installation and commissioning please leave these operating instructions with the customer.

HETAS LTD APPROVAL

These appliances have been approved by HETAS Ltd as an intermittent operating appliance for burning the fuels listed on page 12.

Recommended fuels

SOLID FUEL

The recommended fuels for this stove are **broad based long flame** fuels as burnt on an open fire. 'Homefire' or 'Ancit' are such fuels. However, if you have any queries consult your Approved Coal Merchant Scheme member for types and availability.

Suitable Fuels

- * Mineral smokeless fuels which are HETAS approved and do not have greater than 20% petro coke, e.g. Ancit.
- * Anthracite is a hard shiny coal that is naturally smokeless. Use the large nut size.

Unsuitable Fuels

- * Do not burn pure Petro coke.
- * Do not burn household plastics and waste.
- * Do not burn liquid fuels.

WOOD

If wood is the chosen fuel for your stove, ALWAYS BURN DRY WOOD. Wood burns **best on a bed of ash** so do be careful to retain some when de-ashing. Dry wood means that it has most **definitely not more than 20% moisture** content. Wood to be used as a fuel should be logged, chopped and **stored in a sheltered but airy site** for an absolute minimum of 12 months and **preferably 24 months**. Wood naturally dries at the rate of 1" per year so a 12" round will take 6 years to dry to the centre. **Do not be tempted to stack wet wood on or around the stove** believing this will dry the sap out of the wood. A 12" log takes approx 8 weeks in a kiln to dry to 18% moisture - so the odd hour or two on or by the stove only increases the likelihood of burning your house down! **Freshly cut green wood** - i.e. wood that still has sap in it - **is dangerous to burn**. It will cause a chimney to choke with wood tar in a few weeks with a grave risk of a chimney fire resulting. In any case, **burning sap wet wood is pointless**. It produces far less heat, maybe as little as 10% of that of dry wood.

Treat any bought in wood as wet unless its history is known.

Do not burn wet wood with solid fuel as a very aggressive acid is created which is lethal for the stove, chimneys and flues.

Do not burn treated wood.

Tar is caused by burning wet wood. It is brown/black in colour and may be liquid. It has an offensive smell. On the sides of the stove, flue and chimney it resembles a black sticky 'chewing gum' and can eventually block the flue ways. When it ignites, it can cause a chimney fire and be highly dangerous.

Please note that HETAS Ltd Appliance Approval only covers the use of the above fuels on these appliances. HETAS Ltd Approval does not cover the use of other fuels either alone or mixed with the recommended fuels listed above, nor does it cover instructions for the use of other fuels.

DAILY ROUTINE , MAINTENANCE AND SERVICING

When properly used a Woodwarm stove is absolutely safe.

There is an **operating tool** provided to **operate all the various controls**. **Do not leave the operating tool attached to the stove when the stove is in use as it will get very hot**. Obviously when the stove is in use the body will be too hot to touch by hand. Children and elderly people should be prevented from touching it by accident by using a suitable fire guard. This should be manufactured to BS 6539.

Combustible materials should never be left on the stove when it is alight. Linen, wool, wood and many other materials can spontaneously ignite if they become too hot. They do not have to come in direct contact with flames.

Never spray aerosols near the stove when it is alight as an explosion could occur if flammable vapours or gases come into contact with naked flames.

A routine should be established of :-

Daily - run the stove **hot for a time** using the procedure as explained on pages 12 and 13, along with a surface mounted thermometer to ensure optimum temperature is reached. This will assist in cleaning any marginal deposits of tar from the door glass, stove, flue and chimney internally. Check on the amount of ash in the ashpan and empty if necessary.

Weekly - check seals, be they rope or fire cement, for air tightness. **LUBRICATE** the **fire door catch** if needed with a high temperature or graphite based lubricant. Ensure that the ashpit is clear of ash all the way to the rear, remove the ashpit baffle (diagram 7) by pulling it forward and remove any ash from the air way. Clear any clinker or nails from the grate bars and from the front and rear grate bar supports.

Diagram 7

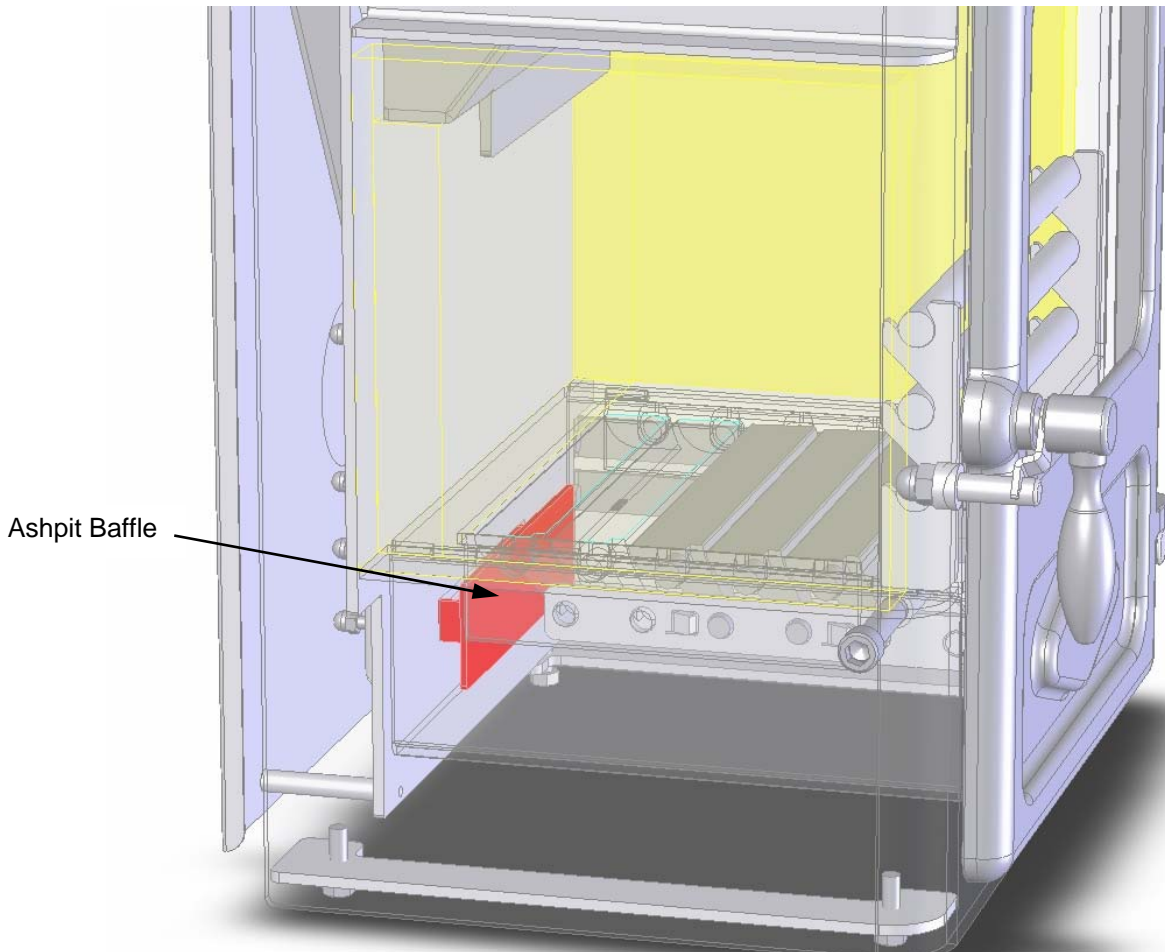

Twice yearly - check the condition of the fire boards and seals and replace if deteriorated. Remove and clean over the baffle and clear flue ways. More often if burning solid fuel. A visit from the chimney sweep will remove the small amount of ash dust which forms in the chimney if the above instructions are adhered to.

The names and addresses of your local Approved Chimney Sweeps can be obtained from either of the following:- Guild of Master Sweeps or The National Association of Chimney Sweeps (see page 19 for contact details).

If the stove is to be left unlit for any period of time ensure the **air vents are left open** and the **controls and door catches are well lubricated** with a high temperature/graphite based lubricant or other rust preventative. Maintain the paint surface solely with a soft dry cloth and nothing more. The paint used is a durable heat proof paint. It is, as a consequence, porous and is not waterproof. Before re-lighting the stove after a long period out of use, check that **all flue ways are clear** of obstructions.

OPERATING INSTRUCTIONS FOR THE WOODWARM FIREVIEW STOVES

Before lighting check with the installer that the work and checks described in the previous pages of this booklet have been carried out correctly and that the chimney is sound, has been swept and is free from any obstructions.

HOW CLEAN BURN WORKS

The stoves utilise long preheated air inlet ducts venting the air to the stove at the front top of the door aperture. This method of air inlet builds an '**Air Curtain**' over the glass and prevents all but a little of the normal tar deposits from condensing on the glass of the stove, and causes all, but a small proportion, to be burnt in secondary combustion, hence the '**CLEAN BURN**' application.

INITIAL LIGHTING

Note The paint used for finishing the stove will emit fumes as it "cures" when first fired, and maybe on the second firing, as the body of the stove reaches operating temperature. Therefore ensure the room is well ventilated. As part of the process the paint **will soften whilst "curing" so avoid touching as this will severely mark the finish.**

LIGHTING

Open the secondary control using the lever on the right hand side of the stove by pushing it lifting and moving it backwards. Open the primary air control the lever positioned below the secondary air lever. Make sure that the exterior of the stove is thoroughly cleaned using a dry cloth. The stove can be lit using paper, dry kindling, and/or fire lighters. Place the paper and kindling or fire-lighters on the grate and cover with wood or a 50mm layer of solid fuel. Light the fire and close the stove door; wait until the fuel is well alight then load fuel and adjust the air controls to suit as in the following section.

Diagram 8

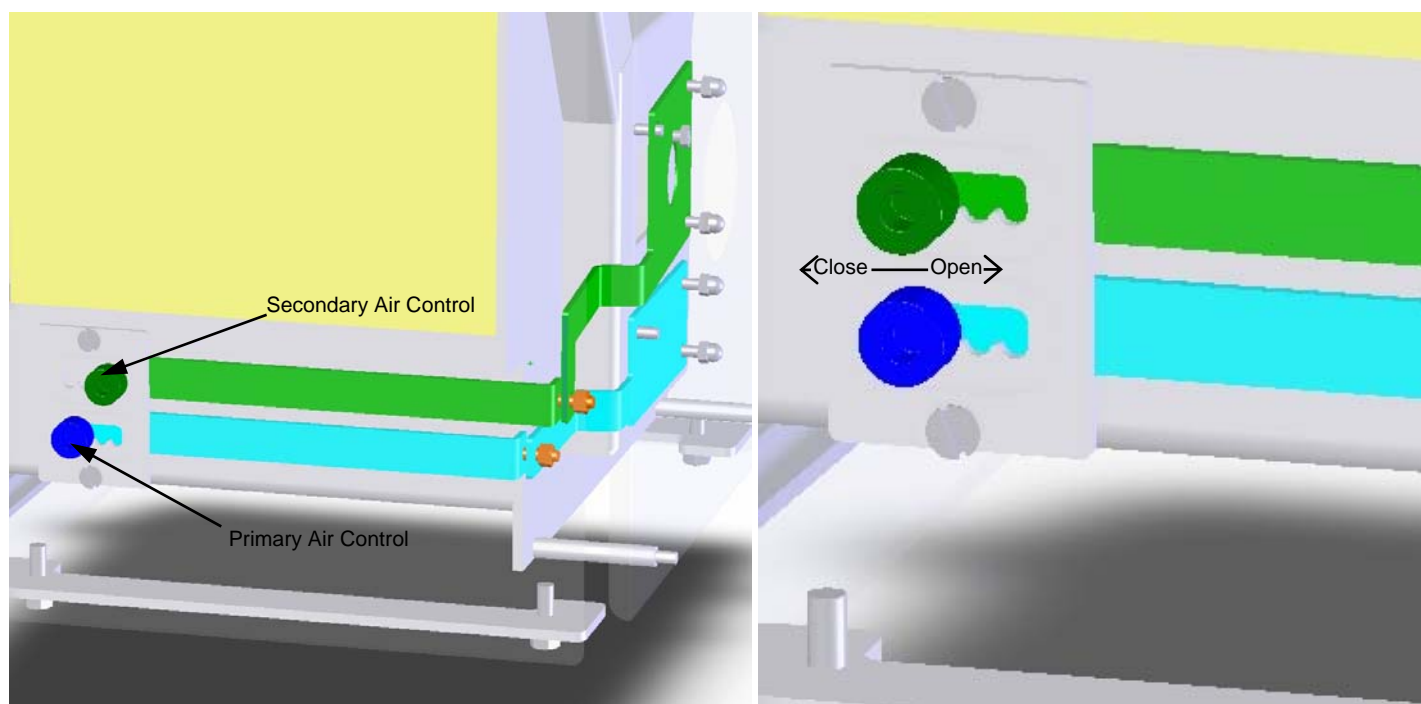

TO ACHIEVE CLEAN BURN

This section applies for the burning of dry wood and to broad based long flame path solid fuels. Take some time to familiarise yourself with the air controls of the stove (diagram 8) to achieve the clean burn state that these stoves are renowned for.

The **air wash** is controlled by the top lever on the right hand side of the stove.

When the lever is **POSITIONED TOWARDS THE FRONT OF THE STOVE** the air wash is **closed**.

When the lever is **POSITIONED TOWARDS THE REAR OF THE STOVE** the air wash is fully **open**.

A) When lighting or refuelling the stove allow it to reach operating temperature every time, before attempting to close the air wash control lever. The glass will get dirty if the stove body has not reached the optimum temperature first and clean burn will not be achieved. We recommend that you use a magnetic surface-mounted **thermometer** (which can be purchased from your supplier or from ourselves) to achieve this.

Regard the primary air control like the choke on a car i.e. close them as soon as the stove is warm.

B) Leave the secondary air control open for about 20 minutes until the surface temperature of the stove body has reached a temperature of 250-280°C (450-500° F), as shown by the thermometer. Slowly close the air wash lever. Although use of the primary air control will increase the draw of the fire, prolonged or excessive use of this under draught will cause dirtying of the glass, and can lead towards excessive over firing of the stove, therefore reduce under draught as soon as is practical.

C) **When refuelling the stove**, first open the secondary air control to increase the draw of the fire and allow the chimney to warm up, this will draw any smoke/fumes up the chimney when you open the main door. To maintain the hot air flow from the front of the stove to the rear, drag any unburnt fuel to the front and add new fuel to the rear. Try and keep the fuel at least 25mm from the door glass when the door is closed and repeat the procedure in B . For recommended refuelling intervals see table 1.

Time spent now will reward you and remarkable results should be achieved. This will be even more apparent to you if you have previously owned a conventionally draughted stove.

It will take a few loadings and firings before you become familiar with the air vents and amount of fuel necessary to achieve the burning rate you require. Try to load the stove with fuel enough i.e. not too small a load and not too large a load.

To be avoided at any time is loading the stove up and immediately closing all the air controls.

Air Bleed Control

A small air bleed hole adjustment is provided, it is located on the airwash flap on the back of the stove (diagram 9). Its function is to allow you to "Set" the stove to the chimney draught. Open it fully and over the first couple of extended burning periods, monitor the result of your stove's slumber. If it fails to stay alight long enough, by burning through all the fuel too quickly, reduce the setting until you are happy. When you are, tighten up the screw, so that in future when you fully shut the airwash lever this hole will allow the stove to remain just open. Chimneys with a high draw may require this small air bleed hole to be closed.

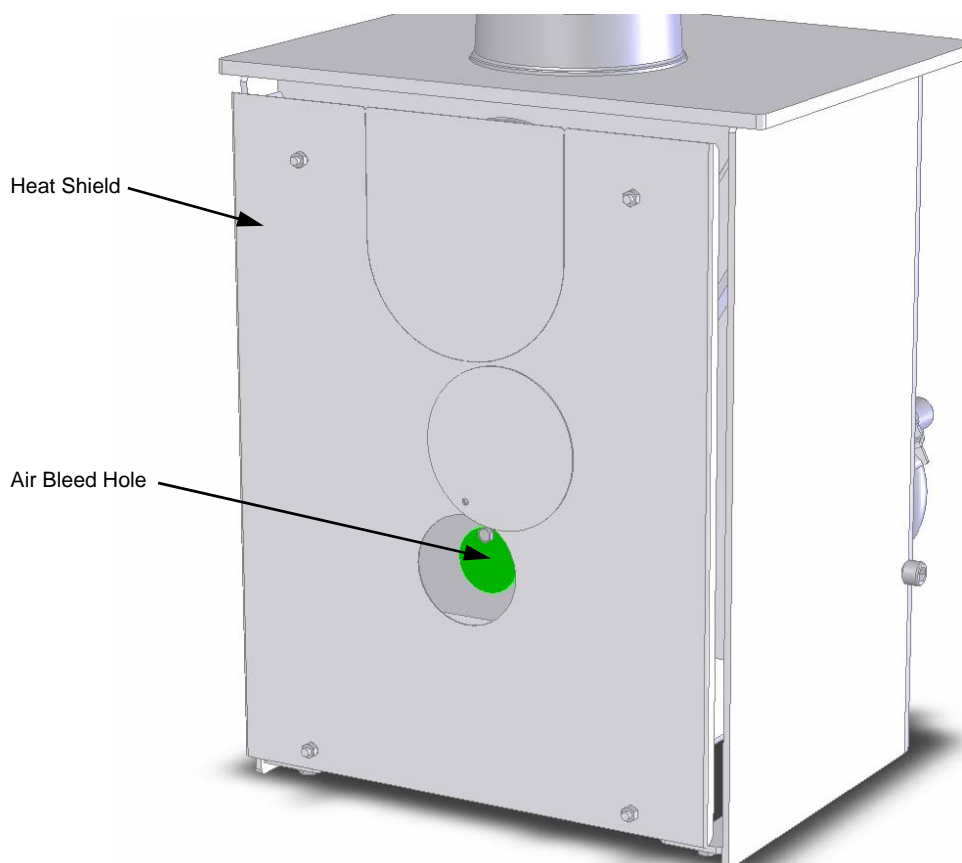

Diagram 9

Chimney Fires

If the chimney is thoroughly and regularly swept, chimney fires should not occur. However, if a chimney fire does occur turn the air control setting to the minimum, and tightly close the doors of the stove. This should cause the chimney fire to go out in which case the control should be kept at the minimum setting until the fire in the stove has gone out. The chimney and flue ways should then be cleaned. If the chimney fire does not go out when the above action is taken then the fire brigade should be called immediately.

After a chimney fire the chimney should be carefully examined for any damage. Expert advice should be sought if necessary.

EXTENDED BURNING PERIODS

When burning **solid fuel** the stove should be de-ashed, the bottom air controls opened for a brief period and when the fire is burning brightly it should be loaded with fuel without dowsing the flames. The bottom air controls should then be closed. The stove will burn more slowly if a smaller size of solid fuel is used.

The opposite is true when burning **wood**, thus if longer burning times are required use **dry** large logs of a hard wood rather than small ones, remembering to keep a bed of ash above the grate bars.

Some fuels need more air than others to tick over, some experimentation will be necessary to find the right setting.

Do not mix solid fuel with wet wood in an attempt to achieve long periods of burning.

Remember to allow the stove to reach operating temperature before closing air controls.

FAULT FINDING

A) Stove smokes on lighting or when fire door is opened

Flue ways blocked - sweep chimney and flue.

Baffle incorrectly fitted.

Adverse wind conditions, or down draught - check height and diameter of chimney.

Flue not connected (or not sealed) to appliance or chimney .

B) Fire fails to burn overnight - fuel burnt through

Insufficient dry fuel.

Air supply too great for fuel load.

Fire door or ash door seals damaged.

Door adjustment too slack.

Door glass sealing rope damaged or missing.

Insufficient bed of wood ash (when burning wood).

C) Fire fails to burn overnight - fuel not burnt

Insufficient air supply for fuel load.

Wood fuel beyond 18% moisture content and therefore too wet.

All section **A** applies also.

Grate closed or ashpan full whilst burning solid fuel.

Fuel load not raised to a high enough temperature before closing to slumber.

D) Stove cannot be closed to slumber and fuel burns too fast

Air controls open.

If the above are closed and/or shut then **air is getting into stove** from elsewhere.

Check if door, glass and ashpit door rope seals are damaged or not seating.

If rear flue outlet is being used, is the flat top / canopy seated on correctly.

Check all flue connections are airtight. Check if flue blanking plate is airtight.

Go through installation procedures and cautionary notes.

Chimney draw too fast - fit flue stabiliser.

E) Door glass sooting up

Allow stove to reach body temperature before closing air wash.

Primary air inlets on open, whilst Secondary air control is shut.

Use bottom air as choke only - i.e. **minimal use**.

Fuel load too close to the door.

FUME EMISSION

WARNING NOTE: WHEN PROPERLY INSTALLED AND OPERATED THIS APPLIANCE WILL NOT EMIT FUMES OR SMOKE TO THE ROOM. OCCASIONAL FUMES FROM DE-ASHING AND RE-FUELLING MAY OCCUR. PERSISTENT FUME OR SMOKE EMISSION TO THE ROOM MUST NOT BE TOLERATED. IF EMISSION DOES PERSIST THEN THE FOLLOWING IMMEDIATE ACTION MUST BE TAKEN.

- A OPEN ALL DOORS AND WINDOWS TO VENTILATE THE ROOM**
- B LET THE FUEL OUT AND SAFELY DISPOSE OF FUEL FROM THE APPLIANCE**
- C CHECK FOR FLUE OR CHIMNEY BLOCKAGE AND CLEAN IF NECESSARY**
- D DO NOT ATTEMPT TO RELIGHT THE FIRE UNTIL THE CAUSE OF THE FUMES HAS BEEN IDENTIFIED, IF NECESSARY SEEK PROFESSIONAL ADVICE**

THE WOODWARM STOVES GUARANTEE

Metal Developments Ltd offer a five year guarantee which covers the main structure of the stove including the construction and quality of workmanship.

In the unlikely event of any failure we will replace any defective part free of charge, labour cost excluded.

This guarantee is invalid if the stove is not assembled, installed or operated as per these instructions or does not comply with current building regulations and any regional legislation in force at the time.

Metal Developments Ltd does not guarantee the onsite assembly, installation or operation of the stove. Please seek advise from your stove supplier / installer for any relevant guarantees applicable to the installation.

Metal Developments Ltd will not be held liable for any consequential or incidental loss, damage or injury, however caused.

Claims under this guarantee should be first made through your Woodwarm Stove retailer.

This guarantee is only applicable in the UK.

Nothing in this guarantee shall effect your statutory rights.

Exclusions

The following consumable parts are not covered by this guarantee : -

Swivel Fire Bars, Logguard, Baffle Plate, Operating Tool, Fire Boards, Glass Panels and Door Seals.

Paint is also excluded from the guarantee as it will eventually deteriorate due to the normal working of the stove.

Your assistance is requested by filling in and returning the product Registration and Guarantee Form, this will help maintain our records and assist us in identifying your stove in the unlikely event of any problem occurring and also when you need to order any spare parts.

**DETAILS OF PRODUCT REGISTRATION
FOR OWNER RETENTION**

MODEL NUMBER AND SERIAL NUMBER OF STOVE M ---

(Found on the data plate located on the pull-out plate on right hand underside of stove also on the front of this booklet)

Date of Purchase / 20.....

Date of Installation / 20.....

SUPPLIERS DETAILS

Suppliers Invoice Number.....

Name.....

Address.....

.....

.....

Phone Number.....

INSTALLERS DETAILS

Name.....

Address.....

.....

.....

Phone Number.....**HETAS Registration Number**.....

SPARE PARTS

Use only Metal Developments Ltd approved replacement parts.

14mm Main Fire Door Rope	State model
14mm Ash Door Rope	State model
Door Glass Ladder Rope	State model
Door Glass (2no per stove)	State model and number required
Fire Boards	State model and see chart (30mm)
Operating Tool	State model
Grate Link Bar	State model
Swivel Grate Bar	C305 - State No Req.
Door Hinge Pin	State model
Ash Pan	State model
Baffle	State model
Log Guard	State model

Useful Contacts

HETAS

PO Box 37
Bishops Cleeve
Gloucestershire
GL52 9TB
www.HETAS.co.uk

Solid Fuel Association

The Old School House
Church Street
Sutton In Ashfield
Nottinghamshire
NG17 1AE
Tel: 0800 600000

Guild of Master Sweeps

Tel: 01953 451322
www.guild-of-master-sweeps.co.uk

The National Association of Chimney Sweeps

Unit 15
Emerald Way
Stone Business Park
Stone
Staffordshire
ST15 OSR
Tel: 01785 811732
www.chimneyworks.co.uk

The National Association Of Chimney Engineers

(N.A.C.E. Ltd)
PO Box 849
Metheringham
Lincoln
Lincolnshire
LN4 3WU
Tel: 01526 322555
Fax: 01526 323181
E-mail:info@nace.org.uk

Database of wood fuel suppliers.

National Energy Foundation (NEF)

Tel: 0800 138 0889
www.logpile.co.uk
Searches can be made on post code, county and by supplier.

30/09/09